

SPECIFICATIONS

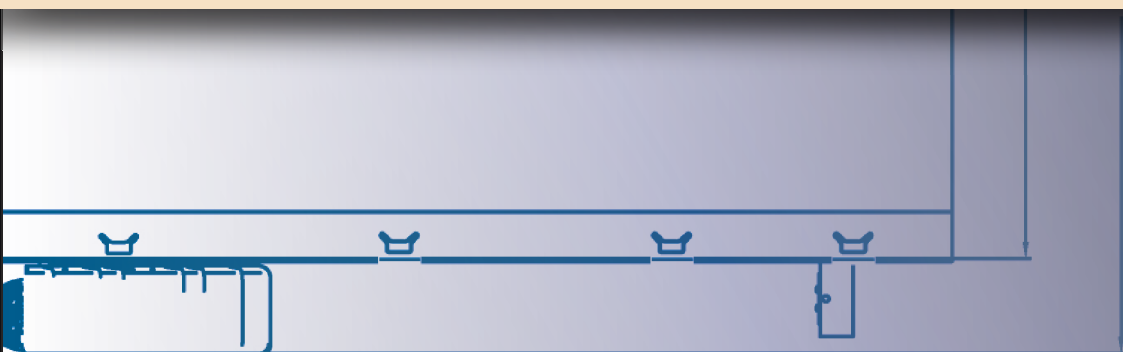

<https://www.EZrampInc.com/>

EZ RAMP 19 SPECIFICATIONS
C.C. STRUCTURAL STEEL

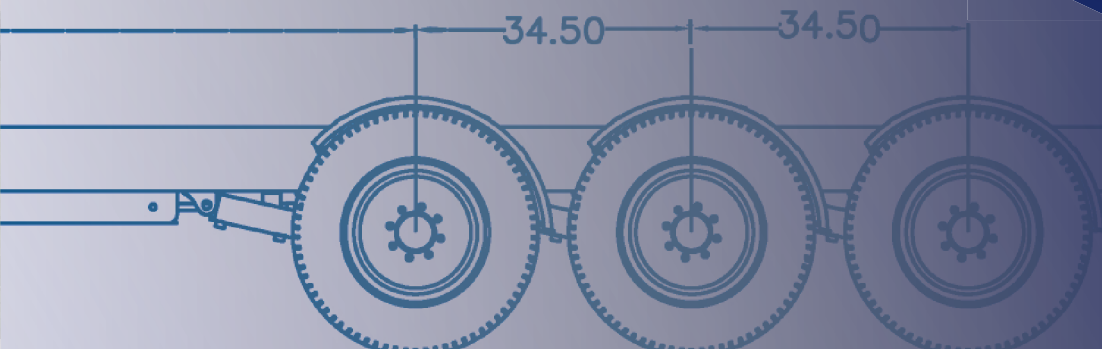

Advanced Designs. Lasting Quality... Every Time.

At PRATT we constantly thrive on achieving your needs through excellent customer service, innovative engineering, the latest manufacturing techniques, and by being on the cutting edge of information technology.

Our business is making you successful in your business. PRATT leads the industry in specialty products, amassing more than 4,000 distinct product builds. And since PRATT-manufactured equipment has the highest resale value in the industry, you can trust that your purchase will meet your needs and protect your investment!

We build lightweight, high strength chassis, which are technically and innovatively engineered. At PRATT we have been building trailers for over 30 years. Over these years, we are constantly improving our Standard models and are simultaneously developing new innovative models.

Our years of experience provide you with quality trailers and excellent service support. Our trailers have the highest retail value in the industry. We make trailers that are heavy duty as well as light weight that gives our customers leading edge in the marketplace.



EZ1065

EZ865 - EZ RAMP TRAILER

8' x 65" deck surface

Specifications

Capacities

- Max Payload 1,690 lbs.
- GVWR 2,990 lbs.
- Trailer Weight 1300 lbs. (Approx.)
- Axle Rating 1 x 3,500 lbs.
- Jack Rating 2,000 lbs.

Dimensions

- Deck Loading Area 8' x 65"
- Overall Length 12'-8"
- Overall Width 7'-3"
- Wheel Size 12"
- Tire Size 5.30-12
- Ball Size 2" Adj. Ball

Electrical

- LED Rubber Mounted Lighting
- Factory Molded Wiring Harness
- Group 27 Battery
- Electric Assist Hydraulic Lift System

Standard Features

- 4" x 4" x 3/16" Structural I-beam Steel Frame
- 2" Structural Angle Crossmembers
- 10 Gauge Steel Decking with Full Length Anti-skid Surface
- Single Torsion Axle Suspension (No Brakes)
- Integrated Safety Chain Holders

Options

- Wireless Remote Control
- 8 Amp On-Board Battery Charger
- Solar Trickle Charger
- Spare Tire Carrier & Wheel Assembly
- Winch Kit
- D-Rings
- Marker Pole Kit
- Stake Pockets
- Aluminum Wheels

**Specifications, materials, and/or options may change without notice.*

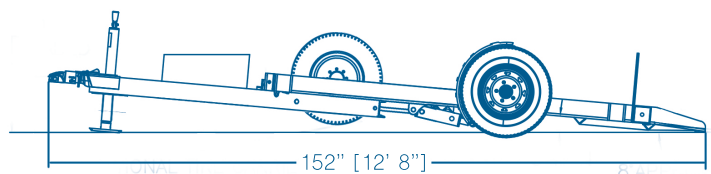
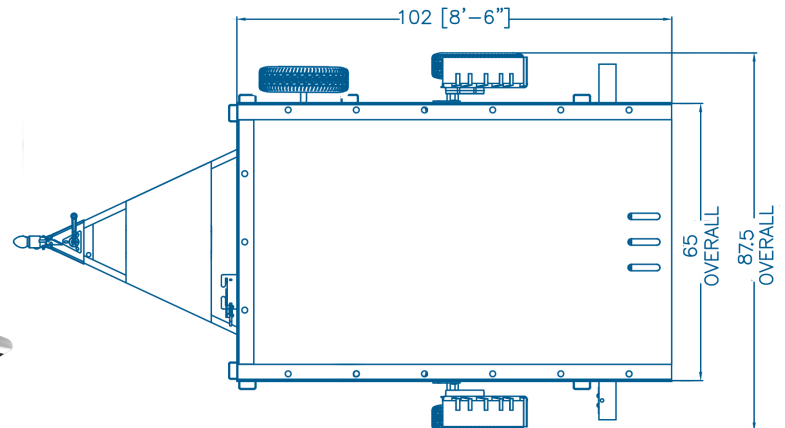

PRATT Industries U.S.
11365 Red Arrow Hwy.
Bridgman, MI 49106

sales@ezrampinc.com
phone : 269.465.7676
fax : 269.465.7677

<https://www.EZrampInc.com/>

Rev 6 2024.04.24





A series of horizontal black lines for writing, filling the majority of the page. A large, faint, italicized "PRATT" watermark is centered across the middle of these lines.

EZ865HD - EZ RAMP TRAILER

8' x 65" deck surface

Specifications

Capacities

- Max Payload 3,400 lbs.
- GVWR 4,800 lbs.
- Trailer Weight 1,400 lbs. (Approx.)
- Axle Rating 1 x 5,200 lbs.
- Jack Rating 2,000 lbs.

Dimensions

- Deck Loading Area 8' x 65"
- Overall Length 12'-8"
- Overall Width 7'-3"
- Wheel Size 15"
- Tire Size ST225/75R15D
- Ball Size 2-5/16" Adj. Ball

Electrical

- LED Rubber Mounted Lighting
- Factory Molded Wiring Harness
- Group 27 Battery
- Electric Assist Hydraulic Lift System

Standard Features

- 5" x 5" x 5/16" Structural Steel Frame
- 4" HSS I-Beam Crossmembers
- 10 Gauge Steel Decking with Full Length Anti-skid Surface
- Single Torsion Axle Suspension
- Electric Drum Brakes
- Integrated Safety Chain Holders

Options

- Wireless Remote Control
- 8 Amp On-Board Battery Charger
- Solar Trickle Charger
- Spare Tire Carrier & Wheel Assembly
- Winch Kit
- D-Rings
- Marker Pole Kit
- Stake Pockets
- Aluminum Wheels

**Specifications, materials, and/or options may change without notice.*

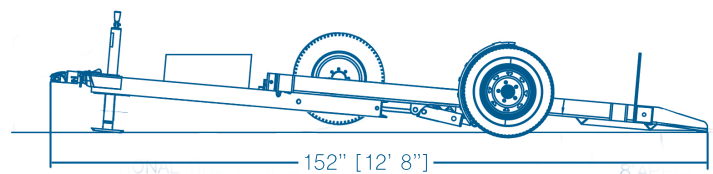
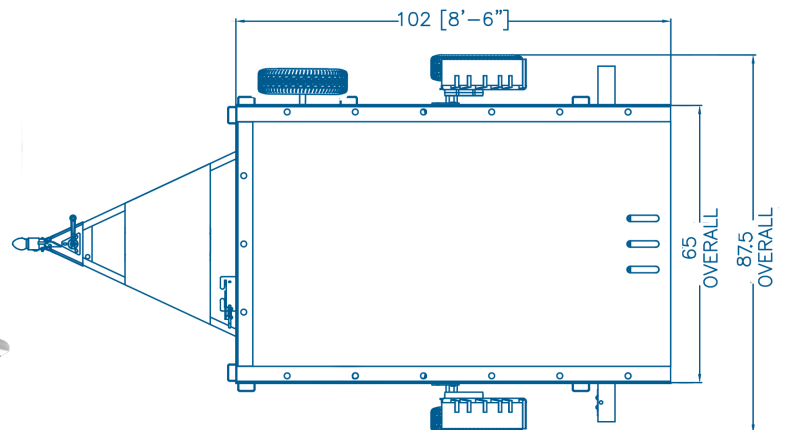

PRATT Industries U.S.
11365 Red Arrow Hwy.
Bridgman, MI 49106

sales@ezrampinc.com
phone : 269.465.7676
fax : 269.465.7677

<https://www.EZrampInc.com/>

Rev 6 2024.04.24





A series of horizontal black lines for writing, filling the majority of the page. The lines are evenly spaced and extend across the width of the page.

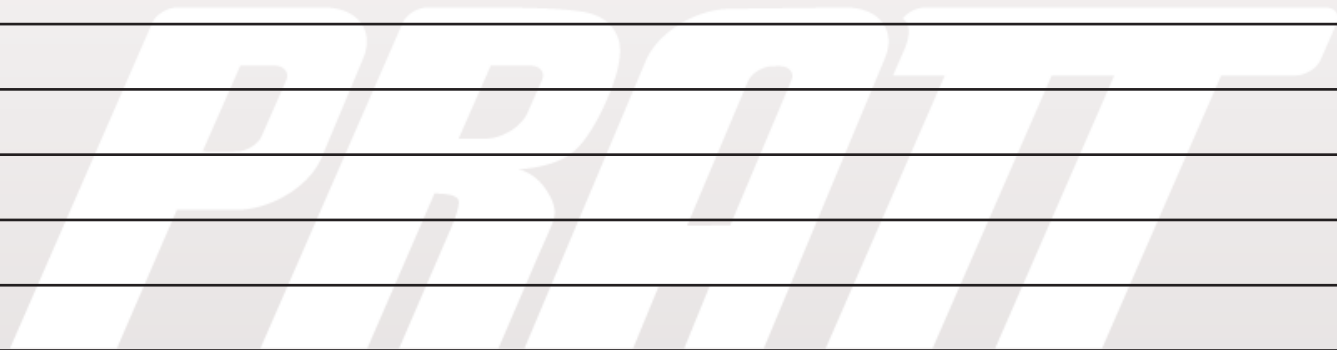

EZ1065 - EZ RAMP TRAILER

10' x 65" deck surface

Specifications

Capacities

- Max Payload 3,500 lbs.
- GVWR 5,100 lbs.
- Trailer Weight 1,600 lbs. (Approx.)
- Axle Rating 1 x 5,200 lbs.
- Jack Rating 7,000 lbs.

Dimensions

- Deck Loading Area 10' x 65"
- Overall Length 15'
- Overall Width 7'-8"
- Wheel Size 15"
- Tire Size ST225/75R15D
- Ball Size 2-5/16" Adj. Ball

Electrical

- LED Rubber Mounted Lighting
- Factory Molded Wiring Harness
- Group 27 Battery
- Electric Assist Hydraulic Lift System

Standard Features

- 5" x 5" x 5/16" Structural Steel Frame
- 4" HSS I-Beam Crossmembers
- 10 Gauge Steel Decking with Full Length Anti-skid Surface
- Single Torsion Axle Suspension
- Electric or Surge Drum Brakes
- Integrated Safety Chain Holders

Options

- Wireless Remote Control
- 8 Amp On-Board Battery Charger
- Solar Trickle Charger
- Spare Tire Carrier & Wheel Assembly
- Winch Kit
- D-Rings
- Marker Pole Kit
- Stake Pockets
- Aluminum Wheels

**Specifications, materials, and/or options may change without notice.*

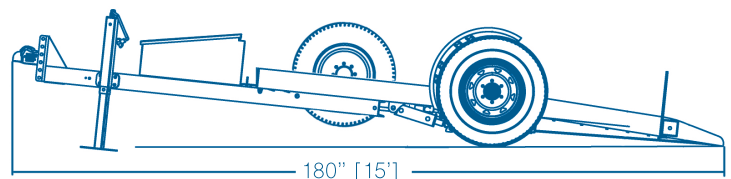
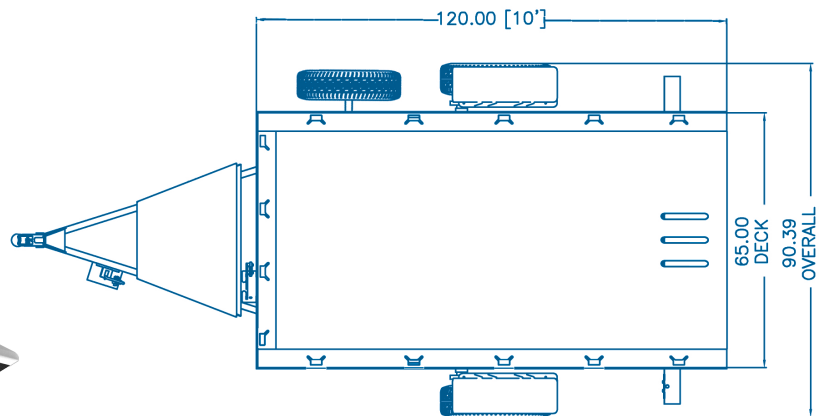

PRATT Industries U.S.
11365 Red Arrow Hwy.
Bridgman, MI 49106

sales@ezrampinc.com
phone : 269.465.7676
fax : 269.465.7677

<https://www.EZrampInc.com/>

Rev 6 2024.04.24





A series of horizontal black lines for writing, filling the majority of the page. A large, faint, italicized "PRATT" watermark is centered across the middle of these lines.

EZ1265 - EZ RAMP TRAILER

12' x 65" deck surface

Specifications

Capacities

- Max Payload 5,000 lbs.
- GVWR 6,800 lbs.
- Trailer Weight 1,800 lbs. (Approx.)
- Axle Rating 1 x 7,000 lbs.
- Jack Rating 7,000 lbs.

Dimensions

- Deck Loading Area 12' x 65"
- Overall Length 17'
- Overall Width 7'-8"
- Wheel Size 16"
- Tire Size ST235/80R16D
- Ball Size 2-5/16" Adj. Ball

Electrical

- LED Rubber Mounted Lighting
- Factory Molded Wiring Harness
- Group 27 Battery
- Electric Assist Hydraulic Lift System

Standard Features

- 5" x 5" x 5/16" Structural Steel Frame
- 4" HSS I-Beam Crossmembers
- 10ga. Steel Decking with Full Length Anti-skid Surface
- Single Torsion Axle Suspension
- Electric or Surge Drum Brakes
- Integrated Safety Chain Holders

Options

- Wireless Remote Control
- 8 Amp On-Board Battery Charger
- Solar Trickle Charger
- Spare Tire Carrier & Wheel Assembly
- Winch Kit
- D-Rings
- Marker Pole Kit
- Stake Pockets
- Aluminum Wheels

**Specifications, materials, and/or options may change without notice.*

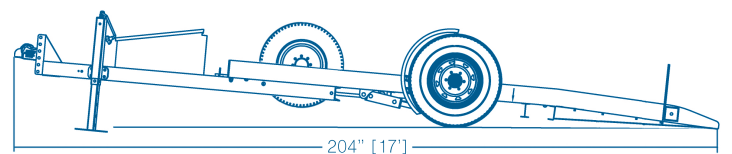
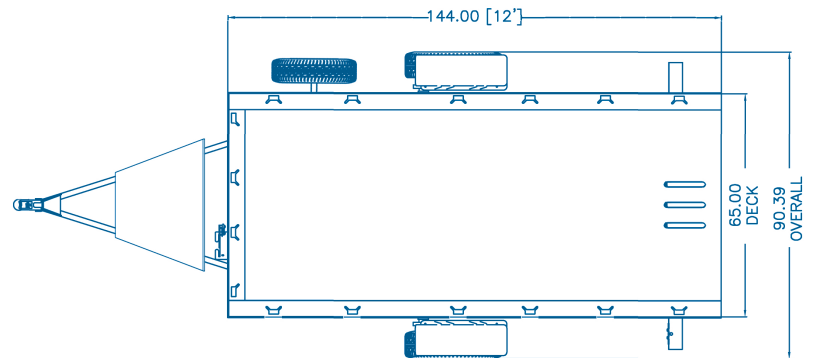

PRATT Industries U.S.
11365 Red Arrow Hwy.
Bridgman, MI 49106

sales@ezrampinc.com
phone : 269.465.7676
fax : 269.465.7677

<https://www.EZrampInc.com/>

Rev 6 2024.04.24





A series of horizontal black lines for writing, filling the majority of the page. The lines are evenly spaced and extend across the width of the page.

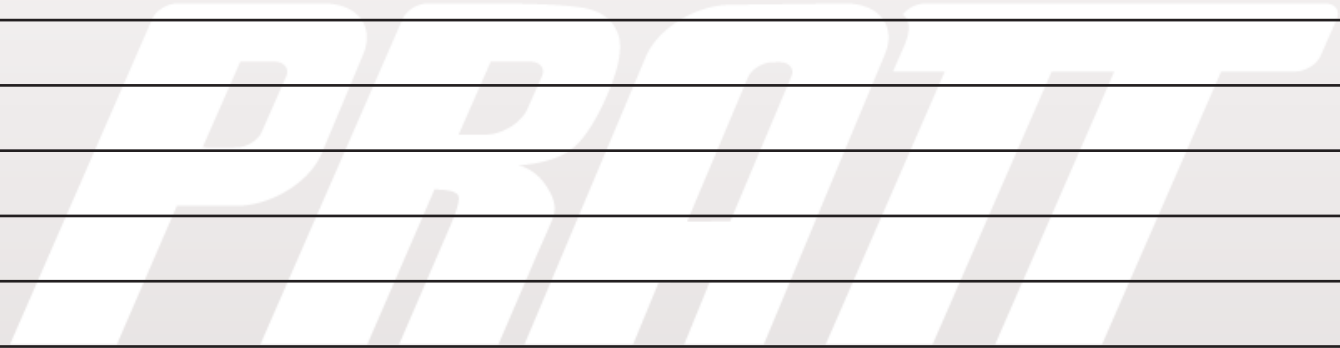

EZ1265T - EZ RAMP TRAILER

12' x 65" deck surface

Specifications

Capacities

- Max Payload 7,000 lbs.
- GVWR 9,500 lbs.
- Trailer Weight 2,500 lbs. (Approx.)
- Axle Rating 2 x 5,200 lbs.
- Jack Rating 7,000 lbs.

Dimensions

- Deck Loading Area 12' x 65"
- Overall Length 17'
- Overall Width 7'-8"
- Wheel Size 15"
- Tire Size ST225/75R15D
- Ball Size 2-5/16" Adj. Ball

Electrical

- LED Rubber Mounted Lighting
- Factory Molded Wiring Harness
- Group 27 Battery
- Electric Assist Hydraulic Lift System

Standard Features

- 5" x 5" x 5/16" Structural Steel Frame
- 4" HSS I-Beam Crossmembers
- 10 Gauge Steel Decking with Full Length Anti-skid Surface
- Twin Torsion Axle Suspension
- Electric or Surge Drum Brakes
- Integrated Safety Chain Holders

Options

- Wireless Remote Control
- 8 Amp On-Board Battery Charger
- Solar Trickle Charger
- Spare Tire Carrier & Wheel Assembly
- Winch Kit
- D-Rings
- Marker Pole Kit
- Stake Pockets
- Aluminum Wheels

**Specifications, materials, and/or options may change without notice.*

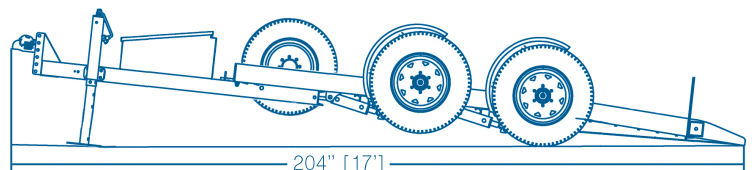
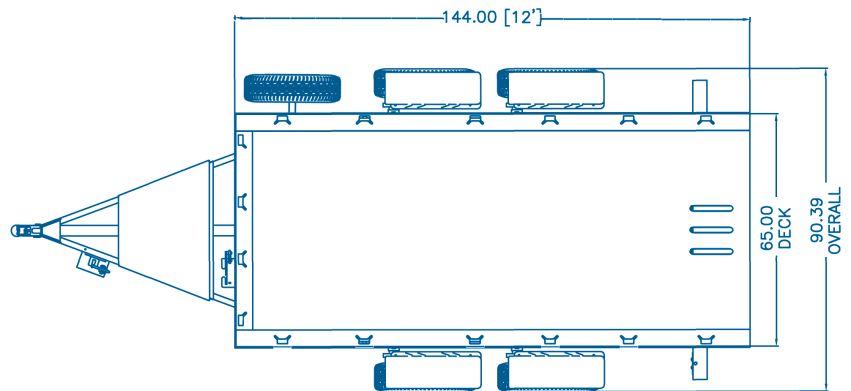

PRATT Industries U.S.
11365 Red Arrow Hwy.
Bridgman, MI 49106

sales@ezrampinc.com
phone : 269.465.7676
fax : 269.465.7677

<https://www.EZrampInc.com/>

Rev 6 2024.04.24





A series of horizontal black lines for writing, filling the majority of the page. The lines are evenly spaced and extend across the width of the page.

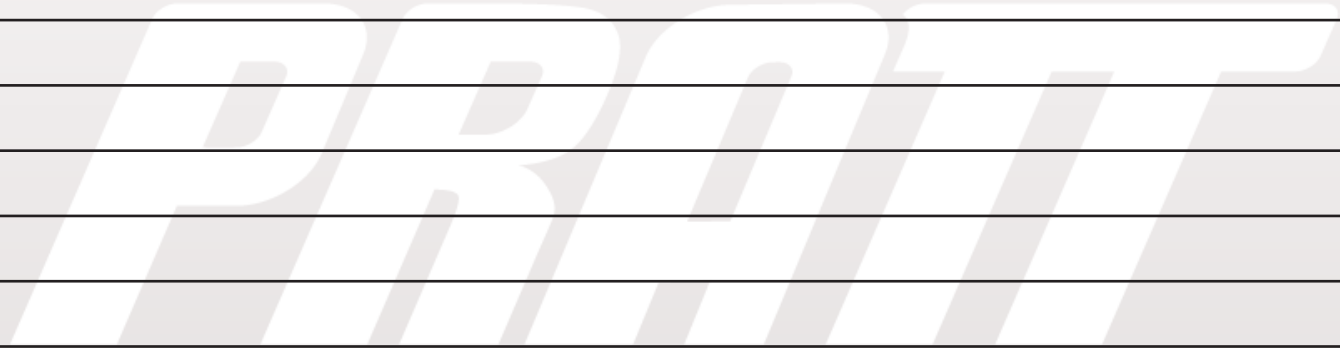

EZ1480 - EZ RAMP TRAILER

14' x 80" deck surface

Specifications

Capacities

- Max Payload 10,000 lbs.
- GVWR 12,800 lbs.
- Trailer Weight 2,800 lbs. (Approx.)
- Axle Rating 2 x 7,000 lbs.
- Jack Rating 7,000 lbs.

Dimensions

- Deck Loading Area 14'-9" x 65"
- Overall Length 19'-9"
- Overall Width 8'-6"
- Wheel Size 16"
- Tire Size ST235/80R16D
- Ball Size 2-5/16" Adj. Ball

Electrical

- LED Rubber Mounted Lighting
- Factory Molded Wiring Harness
- Group 27 Battery
- Electric Assist Hydraulic Lift System

Standard Features

- 6" x 6" x 3/8" Structural Steel Frame
- 4" HSS I-Beam Crossmembers
- 10 Gauge Steel Decking with Full Length Anti-skid Surface
- Twin Torsion Axle Suspension
- Electric or Surge Drum Brakes
- Integrated Safety Chain Holders

Options

- Wireless Remote Control
- 8 Amp On-Board Battery Charger
- Solar Trickle Charger
- Spare Tire Carrier & Wheel Assembly
- Winch Kit
- D-Rings
- 3" I.D. Pintle Coupler
- Marker Pole Kit
- Stake Pockets
- Aluminum Wheels

**Specifications, materials, and/or options may change without notice.*

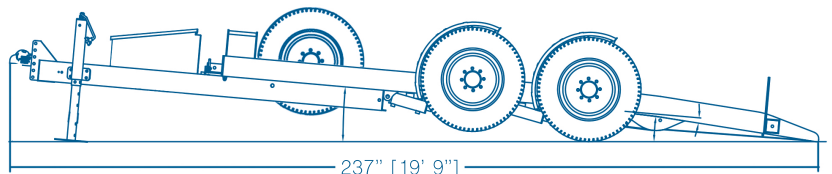
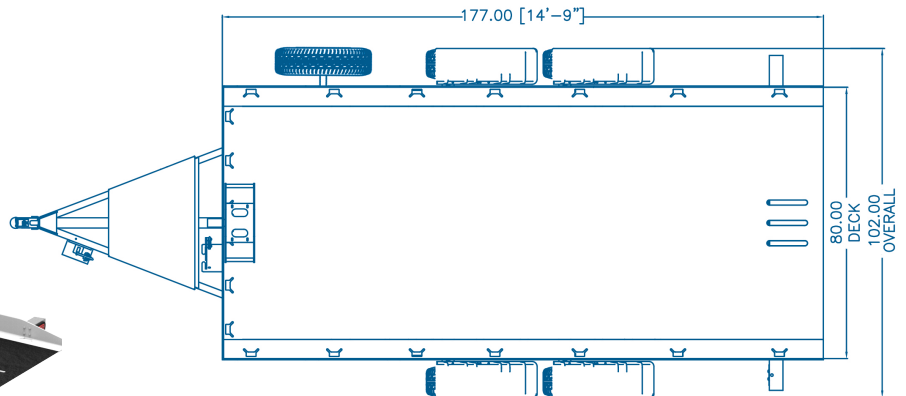

PRATT Industries U.S.
11365 Red Arrow Hwy.
Bridgman, MI 49106

sales@ezrampinc.com
phone : 269.465.7676
fax : 269.465.7677

<https://www.EZrampInc.com/>

Rev 6 2024.04.24





A series of horizontal black lines for writing, filling the majority of the page. A large, faint, italicized "PRATT" watermark is centered across the middle of these lines.

EZ1680 - EZ RAMP TRAILER

16' x 80" deck surface

Specifications

Capacities

- Max Payload 10,000 lbs.
- GVWR 13,100 lbs.
- Trailer Weight 3,100 lbs. (Approx.)
- Axle Rating 2 x 7,000 lbs.
- Jack Rating 7,000 lbs.

Dimensions

- Deck Loading Area 16' x 80"
- Overall Length 21'
- Overall Width 8'-6"
- Wheel Size 16"
- Tire Size ST235/80R16D
- Ball Size 2-5/16" Adj. Ball

Electrical

- LED Rubber Mounted Lighting
- Factory Molded Wiring Harness
- Group 27 Battery
- Electric Assist Hydraulic Lift System

Standard Features

- 6" x 6" x 3/8" Structural Steel Frame
- 4" HSS I-Beam Crossmembers
- 10 Gauge Steel Decking with Full Length Anti-skid Surface
- Twin Torsion Axle Suspension
- Electric or Surge Drum Brakes
- Integrated Safety Chain Holders

Options

- Wireless Remote Control
- 8 Amp On-Board Battery Charger
- Solar Trickle Charger
- Spare Tire Carrier & Wheel Assembly
- Winch Kit
- D-Rings
- 3" I.D. Pintle Coupler
- Marker Pole Kit
- Stake Pockets
- Aluminum Wheels

**Specifications, materials, and/or options may change without notice.*

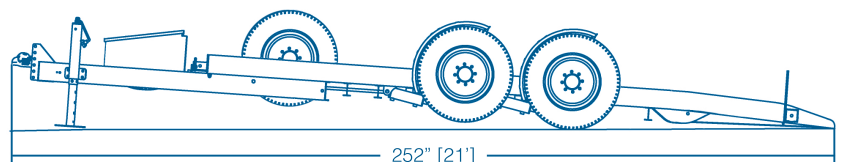
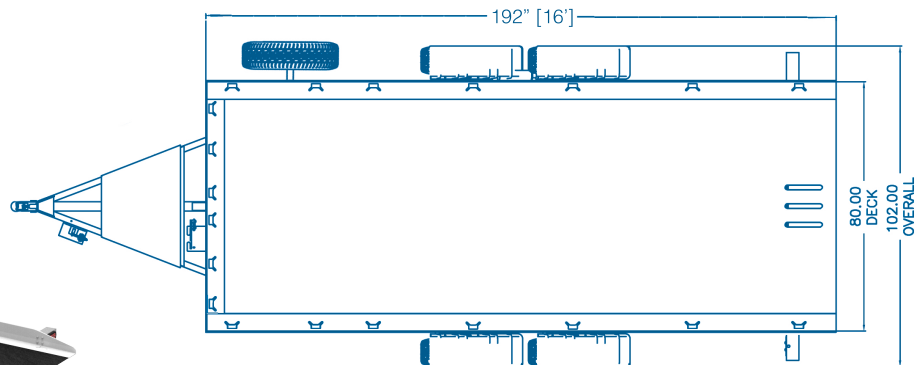

PRATT Industries U.S.
11365 Red Arrow Hwy.
Bridgman, MI 49106

sales@ezrampinc.com
phone : 269.465.7676
fax : 269.465.7677

<https://www.EZrampInc.com/>

Rev 6 2024.04.24





A series of horizontal black lines for writing, starting below the yellow line and extending to the top of the dark blue footer. The lines are evenly spaced and cover most of the page area.

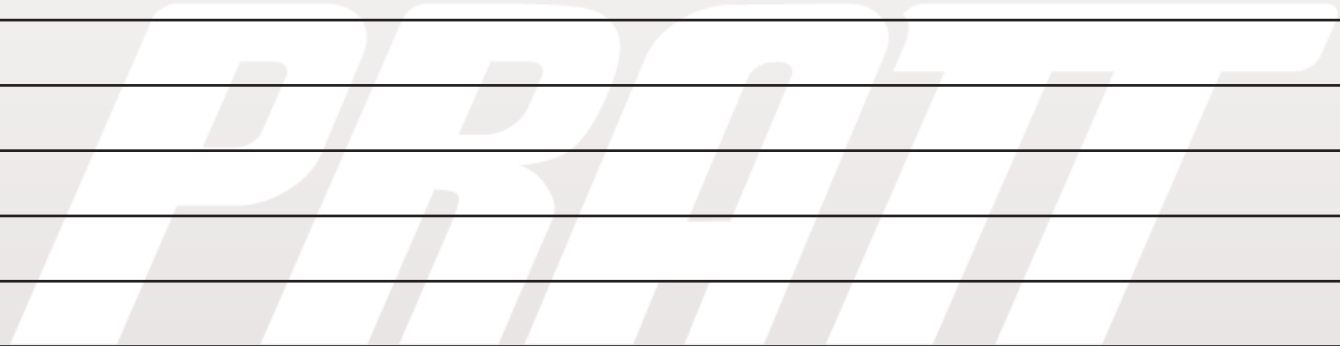

EZ1980 - EZ RAMP TRAILER

19' x 80" deck surface

Specifications

Capacities

- Max Payload 10,000 lbs.
- GVWR 13,325 lbs.
- Trailer Weight 3,325 lbs. (Approx.)
- Axle Rating 2 x 7,000 lbs.
- Jack Rating 7,000 lbs.

Dimensions

- Deck Loading Area 19' x 80"
- Overall Length 24'
- Overall Width 8'-6"
- Wheel Size 16"
- Tire Size ST235/80R16D
- Ball Size 2-5/16" Adj. Ball

Electrical

- LED Rubber Mounted Lighting
- Factory Molded Wiring Harness
- Group 27 Battery
- Electric Assist Hydraulic Lift System

Standard Features

- 6" x 6" x 3/8" Structural Steel Frame
- 4" HSS I-Beam Crossmembers
- 10 Gauge Steel Decking with Full Length Anti-skid Surface
- Twin Torsion Axle Suspension
- Electric or Surge Drum Brakes
- Integrated Safety Chain Holders

Options

- Wireless Remote Control
- 8 Amp On-Board Battery Charger
- Solar Trickle Charger
- Spare Tire Carrier & Wheel Assembly
- Winch Kit
- D-Rings
- 3" I.D. Pintle Coupler
- Marker Pole Kit
- Stake Pockets
- Aluminum Wheels

**Specifications, materials, and/or options may change without notice.*

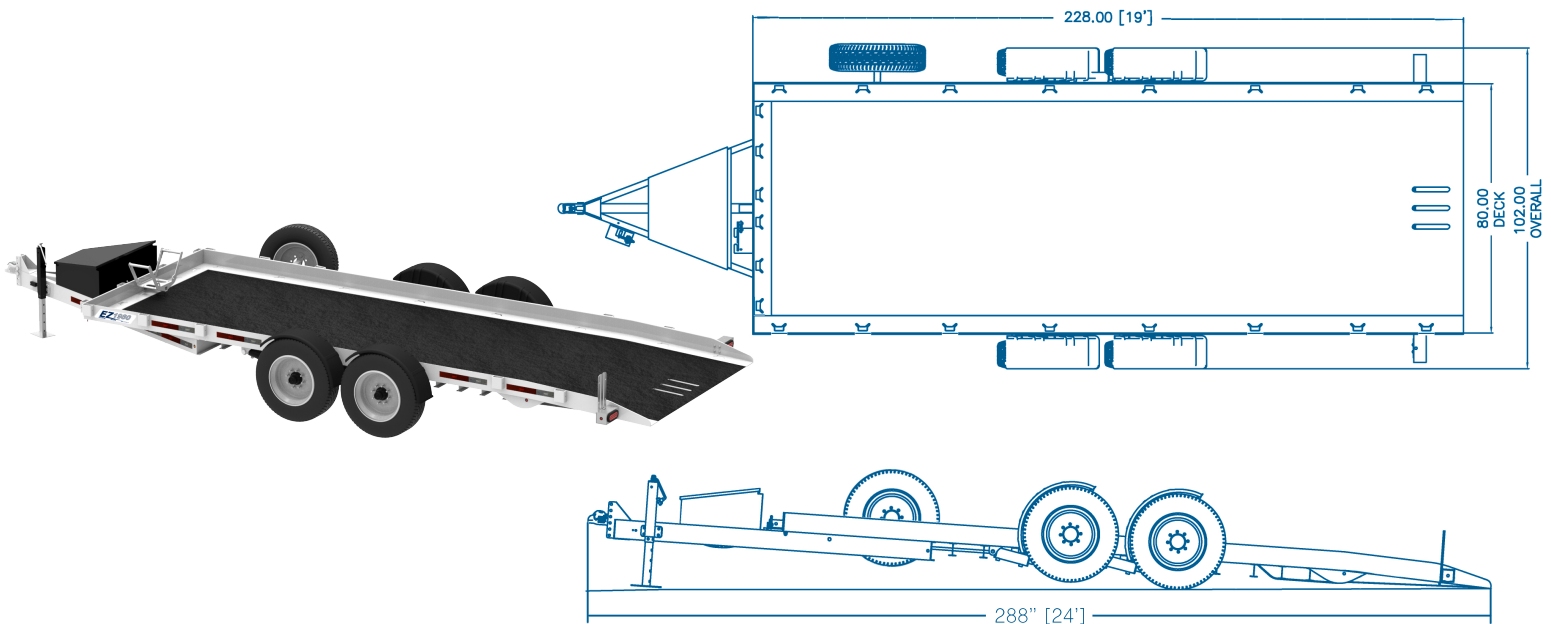

PRATT Industries U.S.
11365 Red Arrow Hwy.
Bridgman, MI 49106

sales@ezrampinc.com
phone : 269.465.7676
fax : 269.465.7677

<https://www.EZrampInc.com/>

Rev 6 2024.04.24





A series of horizontal black lines for writing, filling the majority of the page. The lines are evenly spaced and extend across the width of the page.

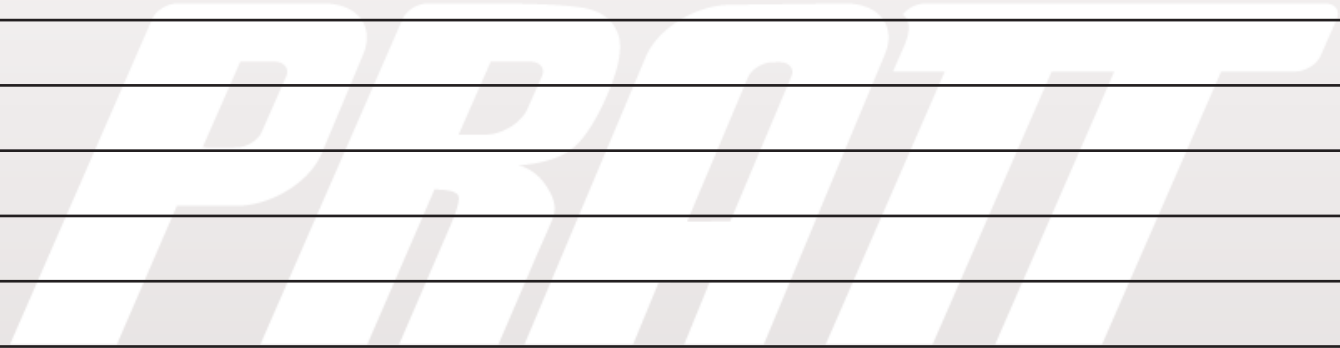

EZ2480 - EZ RAMP TRAILER

24' x 80" deck surface

Specifications

Capacities

- Max Payload 16,000 lbs.
- GVWR 21,000 lbs.
- Trailer Weight 5,000 lbs. (Approx.)
- Axle Rating 3 x 7,000 lbs.
- Jack Rating 12,000 lbs.

Dimensions

- Deck Loading Area 24' x 80"
- Overall Length 29'
- Overall Width 8'-6"
- Wheel Size 17-1/2"
- Tire Size ST215/75R17.5D
- Ball Size 2-5/16" Adj. Ball

Electrical

- LED Rubber Mounted Lighting
- Factory Molded Wiring Harness
- Group 27 Battery
- Electric Assist Hydraulic Lift System

Chassis & Suspension

- 8" x 6" x 1/2" Structural Steel Frame
- 4" HSS I-Beam Crossmembers
- 3/16" Steel Decking with Full Length Anti-skid Surface
- Triple Torsion Axle Suspension
- Electric Drum Brakes
- 18 D-Rings

Options

- Wireless Remote Control
- 8 Amp On-Board Battery Charger
- Solar Trickle Charger
- Spare Tire Carrier & Wheel Assembly
- Winch Kit
- 3" I.D. Pintle Coupler
- Marker Pole Kit
- Stake Pockets
- Aluminum Wheels

**Specifications, materials, and/or options may change without notice.*

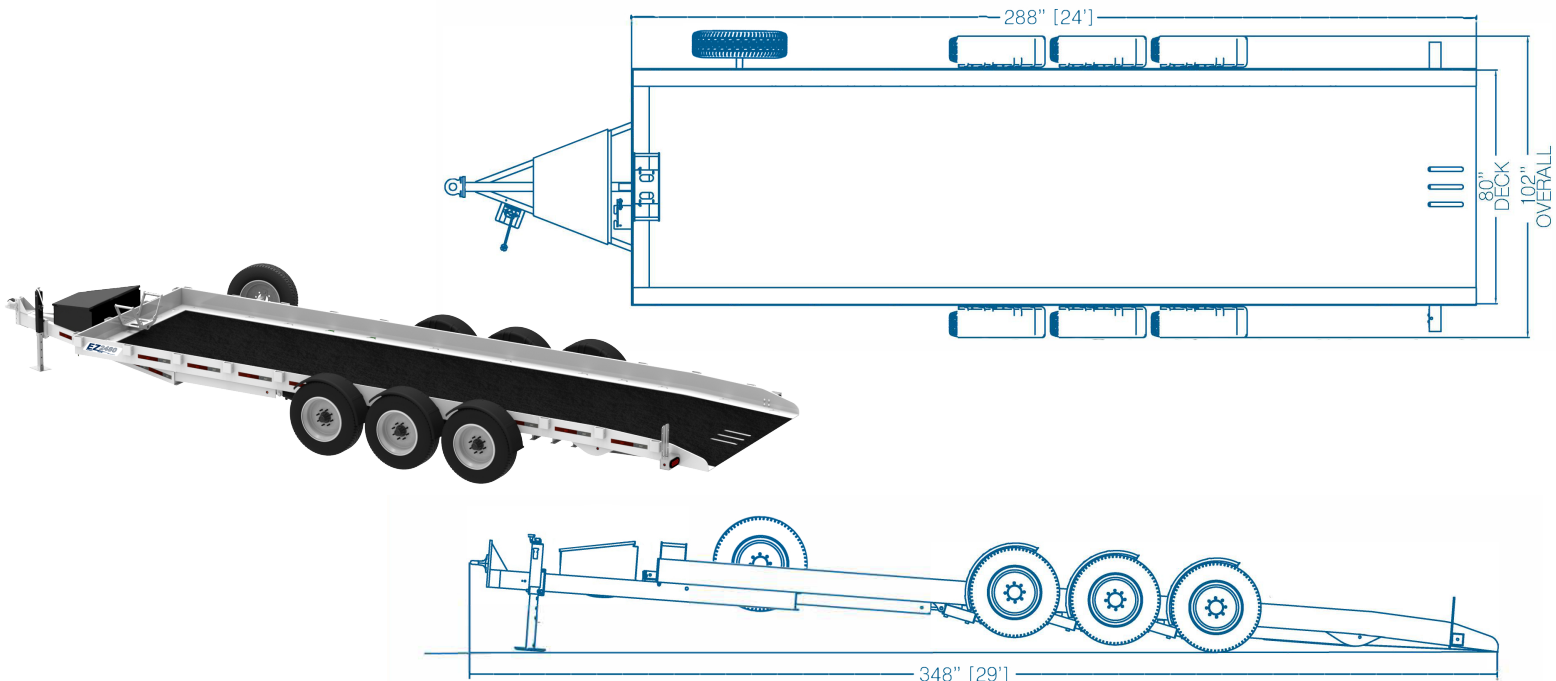

PRATT Industries U.S.
11365 Red Arrow Hwy.
Bridgman, MI 49106

sales@ezrampinc.com
phone : 269.465.7676
fax : 269.465.7677

<https://www.EZrampInc.com/>

Rev 6 2024.04.24





A series of horizontal black lines for writing, filling the majority of the page. The lines are evenly spaced and extend across the width of the page.

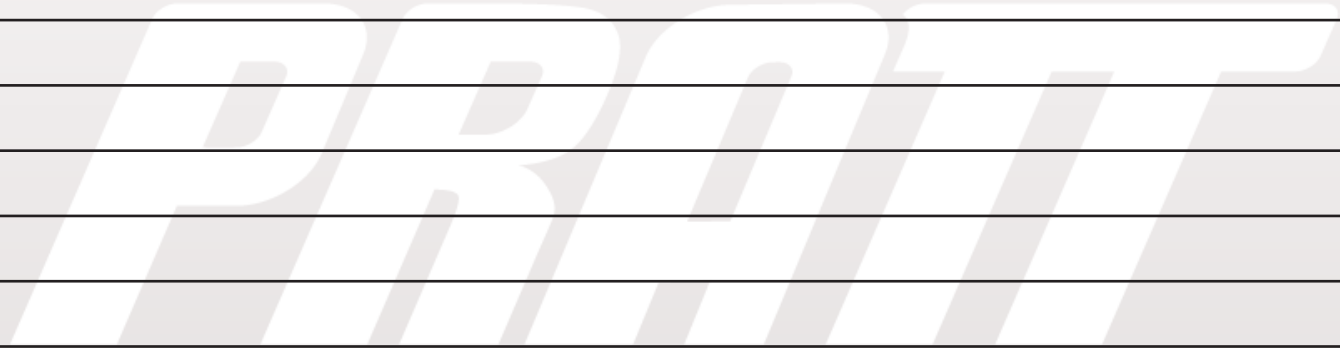

EZ2480GN - EZ RAMP TRAILER

24' x 80" deck surface

Specifications

Capacities

- Max Payload 14,900 lbs.
- GVWR 21,000 lbs.
- Trailer Weight 6,100 lbs. (Approx.)
- Axle Rating 3 x 7,000 lbs.
- Jack Rating 2 x 12,000 lbs.

Dimensions

- Deck Loading Area 24' x 80"
- Overall Length 32'
- Overall Width 8'-6"
- Wheel Size 17-1/2"
- Tire Size ST215/75R17.5D
- Ball Size 2-5/16" Gooseneck

Electrical

- LED Rubber Mounted Lighting
- Factory Molded Wiring Harness
- Group 27 Battery
- Electric Assist Hydraulic Lift System

Chassis & Suspension

- 8" x 6" x 1/2" Structural Steel Frame
- 4" HSS I-Beam Crossmembers
- 3/16" Steel Decking with Full Length Anti-skid Surface
- Triple Torsion Axle Suspension
- Electric Drum Brakes
- 18 D-Rings

Options

- Wireless Remote Control
- 8 Amp On-Board Battery Charger
- Solar Trickle Charger
- Spare Tire Carrier & Wheel Assembly
- Winch Kit
- Marker Pole Kit
- Stake Pockets
- Aluminum Wheels

*Specifications, materials, and/or options may change without notice.

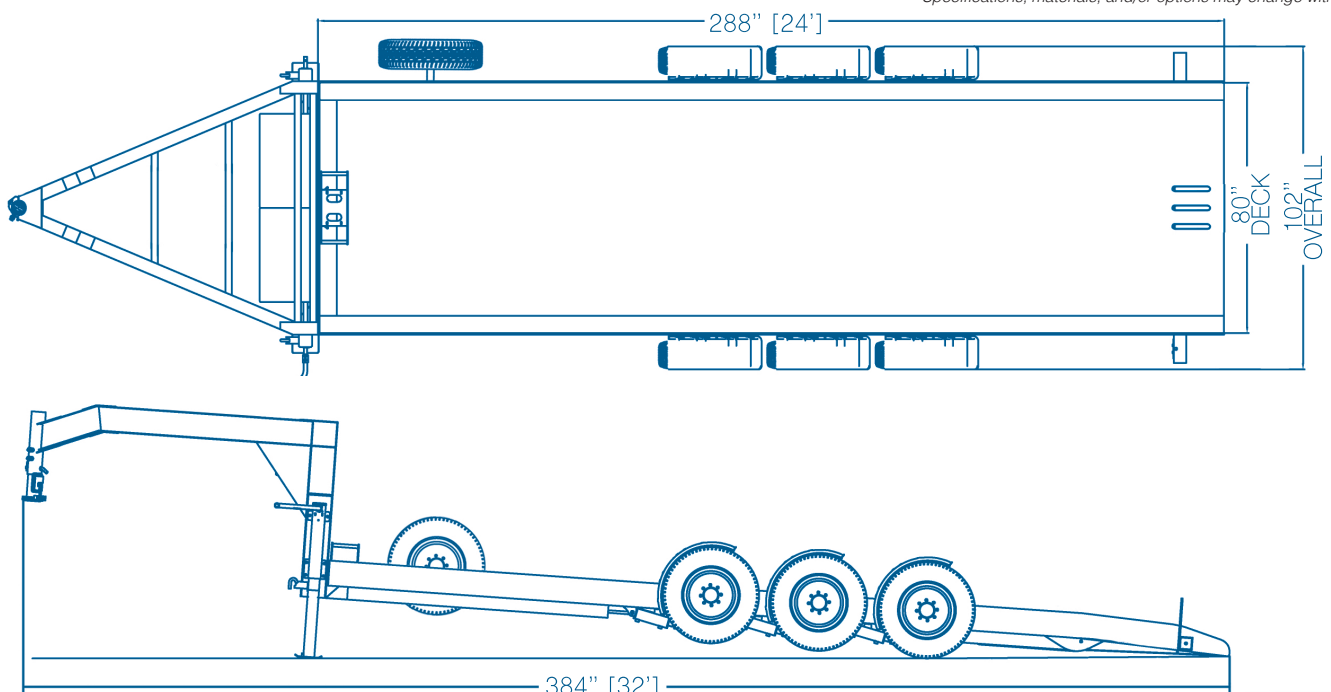

PRATT Industries U.S.
11365 Red Arrow Hwy.
Bridgman, MI 49106

sales@ezrampinc.com
phone : 269.465.7676
fax : 269.465.7677

<https://www.EZrampInc.com/>

Rev 6 2024.04.24





A series of horizontal black lines for writing, filling the majority of the page. The lines are evenly spaced and extend across the width of the page.

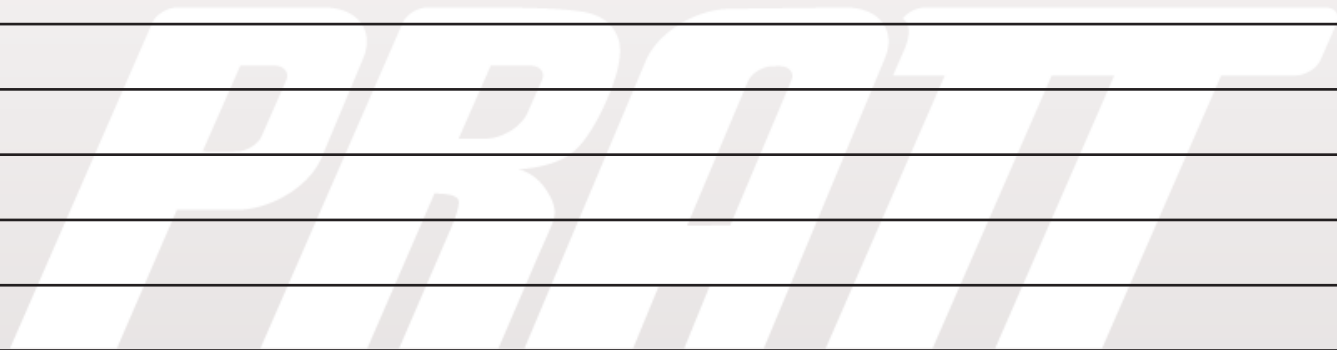

EZU0407 - COMPACT EQUIPMENT TRAILERS

4' x 7' deck surface

Specifications

Capacities

- Max Payload 3,500 lbs.
- GVWR 4,620 lbs.
- Trailer Weight 1,120 lbs. (Approx.)
- Axle Rating 1 x 6,000 lbs.
- Jack Rating 2,000 lbs.

Dimensions

- Deck Loading Area 4' x 7'
- Overall Length 14'-5"
- Overall Width 6'-4"
- Wheel Size 15"
- Tire Size ST225/75R15D
- Ball Size 2" Ball

Electrical

- DOT Compliant LED Lighting
- Factory Molded Wiring Harness

Standard Features

- 3" Steel C-Channel Frame
- 1/8" Steel Tread Plate
- Single Spring Axle
- Hydraulic Drum Brakes
- Powder Coat Paint
- Integrated D-Ring Tie Downs
- Tool Holder Insert
- Manifest & Registration Holder

Options

- Spare Tire Carrier & Wheel Assembly
- Multi-position Load Stop Bar
- Coupler Lock
- Wheel Lock

**Specifications, materials, and/or options may change without notice.*

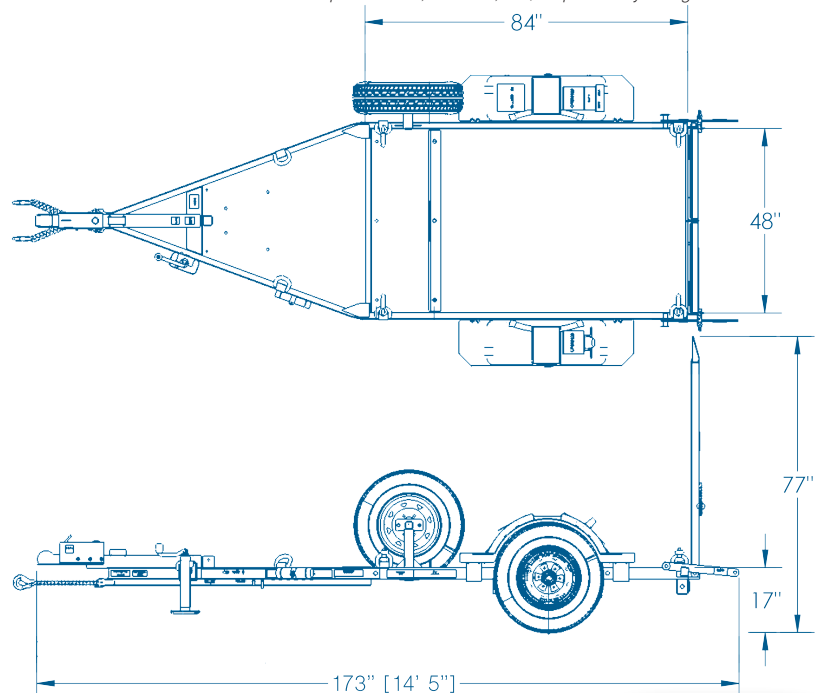

PRATT Industries U.S.
11365 Red Arrow Hwy.
Bridgman, MI 49106

sales@ezrampinc.com
phone : 269.465.7676
fax : 269.465.7677

<https://www.EZrampInc.com/>

Rev 6 2024.04.24

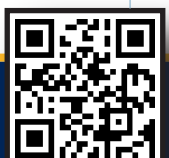



A series of horizontal black lines for writing, filling the majority of the page. The lines are evenly spaced and extend across the width of the page.



EZU0510 - COMPACT EQUIPMENT TRAILERS

5' x 10' deck surface

Specifications

Capacities

- Max Payload 8,430 lbs.
- GVWR 10,400 lbs.
- Trailer Weight 1,970 lbs. (Approx.)
- Axle Rating 2 x 5,200 lbs.
- Jack Rating 7,000 lbs.

Dimensions

- Deck Loading Area 5' x 10'
- Overall Length 16'-5"
- Overall Width 7'-4"
- Wheel Size 15"
- Tire Size ST225/75R15D
- Ball Size 2" Adj. Ball

Electrical

- DOT Compliant LED Lighting
- Factory Molded Wiring Harness

Standard Features

- 4" Steel C-Channel Frame
- 1/8" Steel Tread Plate
- Tandem Torsion Axles
- Hydraulic Drum Brakes
- Powder Coat Paint
- Integrated D-Ring Tie Downs
- Spring Assisted Ramps
- Drop Leg Jack
- Manifest & Registration Holder

Options

- Spare Tire Carrier & Wheel Assembly
- Multi-position Load Stop Bar
- Coupler Lock
- Wheel Lock

**Specifications, materials, and/or options may change without notice.*

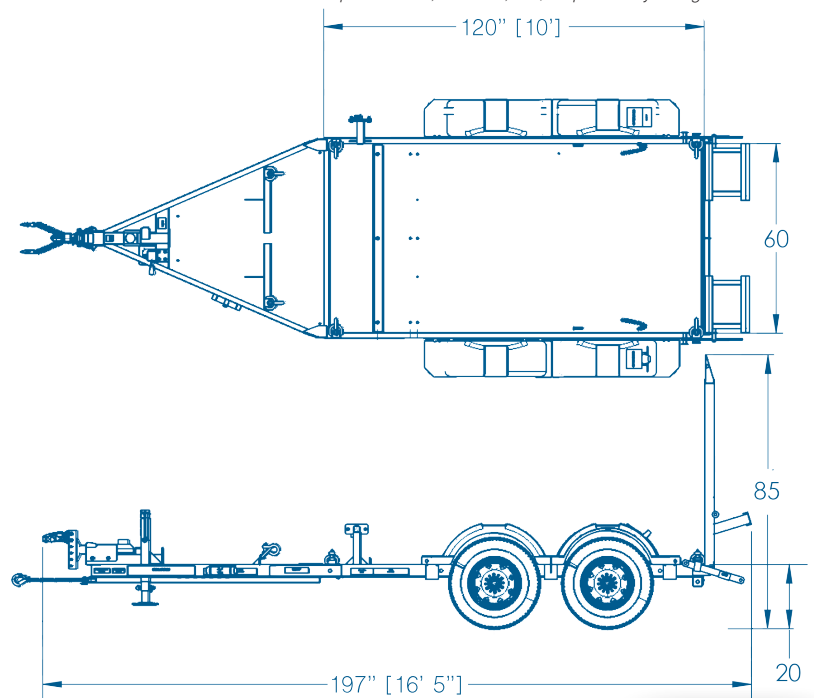

PRATT Industries U.S.
11365 Red Arrow Hwy.
Bridgman, MI 49106

sales@ezrampinc.com
phone : 269.465.7676
fax : 269.465.7677

<https://www.EZrampInc.com/>

Rev 6 2024.04.24





A series of horizontal black lines for writing, filling the majority of the page. A large, faint, italicized "PRATT" watermark is centered across the middle of these lines.

EZU0614 - COMPACT EQUIPMENT TRAILERS

6' x 14' deck surface

Specifications

Capacities

- Max Payload 9,550 lbs.
- GVWR 12,000 lbs.
- Trailer Weight 2,450 lbs. (Approx.)
- Axle Rating 2 x 6,000 lbs.
- Jack Rating 7,000 lbs.

Dimensions

- Deck Loading Area 6' x 14'
- Overall Length 21'
- Overall Width 8'-4"
- Wheel Size 15"
- Tire Size ST225/75R15D
- Ball Size 2-5/16" Adj. Ball

Electrical

- DOT Compliant LED Lighting
- Factory Molded Wiring Harness

Standard Features

- 6" Steel C-Channel Frame
- 1/8" Steel Tread Plate
- Tandem Torsion Axles
- Hydraulic Drum Brakes
- Powder Coat Paint
- Integrated D-Ring Tie Downs
- Spring Assisted Ramps
- Drop Leg Jack
- Manifest & Registration Holder

Options

- Spare Tire Carrier & Wheel Assembly
- Multi-position Load Stop Bar
- Coupler Lock
- Wheel Lock

**Specifications, materials, and/or options may change without notice.*

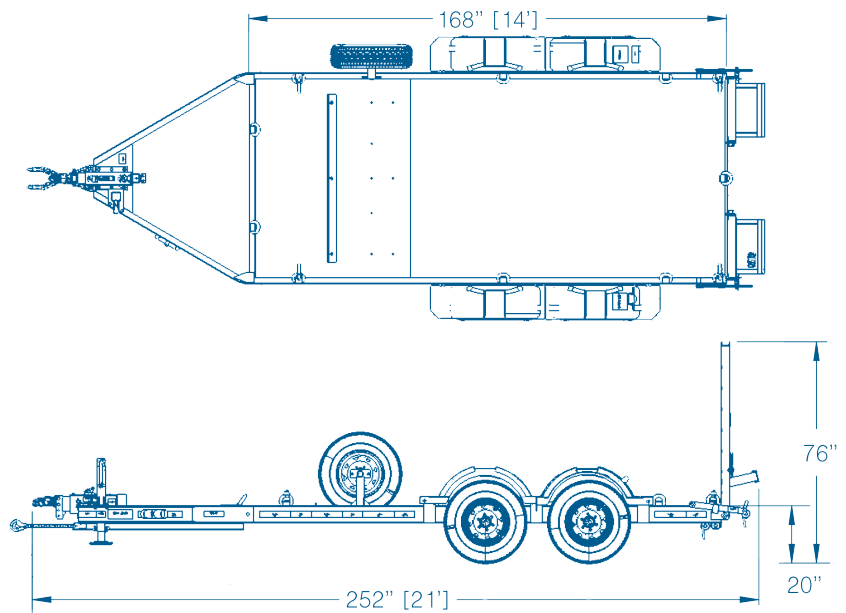
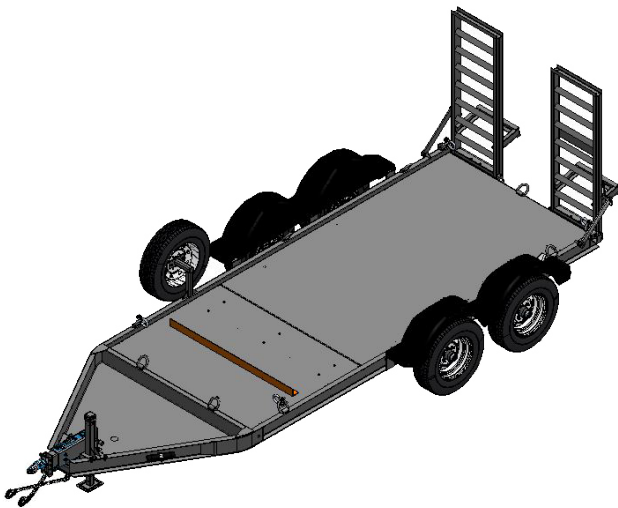

PRATT Industries U.S.
11365 Red Arrow Hwy.
Bridgman, MI 49106

sales@ezrampinc.com
phone : 269.465.7676
fax : 269.465.7677

<https://www.EZrampInc.com/>

Rev 6 2024.04.24





A series of horizontal black lines for writing, filling the majority of the page. The lines are evenly spaced and extend across the width of the page.

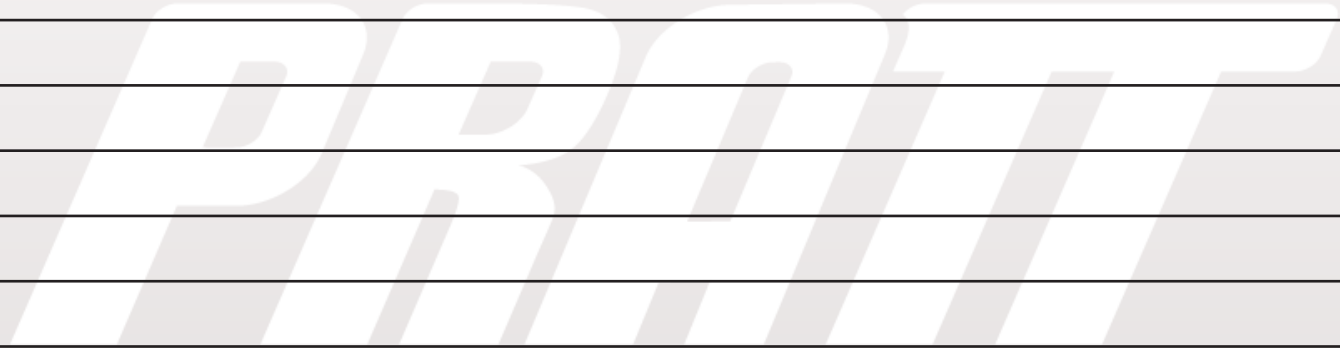

EZU-SW - UTILITY TRAILERS

64" x 98" deck surface

Specifications

Capacities

- Max Payload 1,790 lbs.
- GVWR 2,990 lbs.
- Trailer Weight 1,200 lbs. (Approx.)
- Axle Rating 1 x 3,500 lbs.
- Jack Rating 2,000 lbs.

Dimensions

- Deck Loading Area 64" x 98"
- Overall Length 13'
- Overall Width 7'
- Load Height 21"
- Wheel Size 15"
- Tire Size ST205/75R15D
- Ball Size 2" Ball

Electrical

- DOT Compliant LED Lighting
- Factory Molded Wiring Harness

Standard Features

- 4" x 2" x 11 Gauge Tube Steel Frame
- 2" x 2" x 11 Gauge Tube Crossmembers
- 1/8" Steel Tread Plate Deck
- 14 Gauge Steel Sidewalls
- 24" Sidewalls
- Single Spring Axle (No Brakes)
- Built In Recessed D-Rings

Options

- Coupler Lock
- Wheel Lock
- Spare Tire Carrier & Wheel Assembly

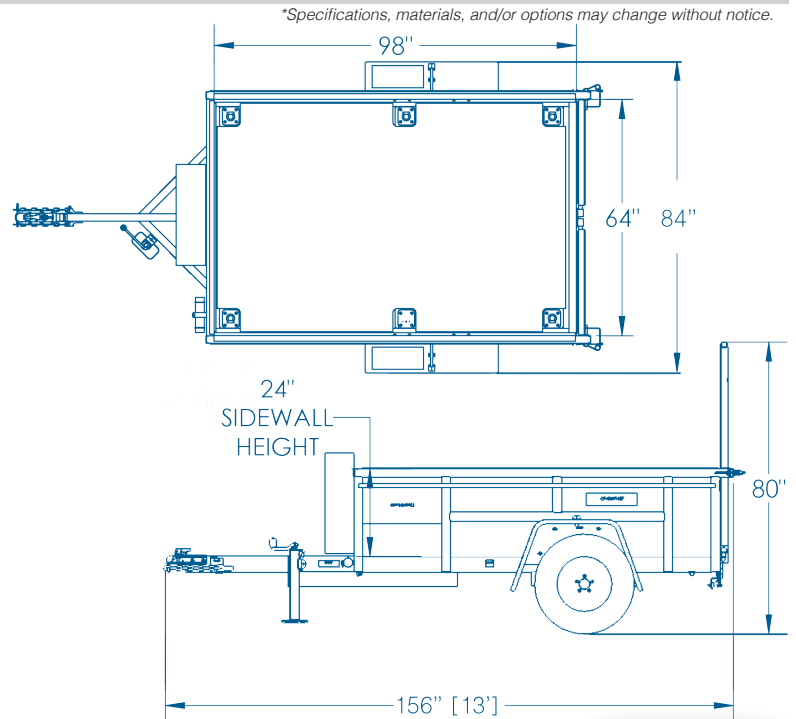
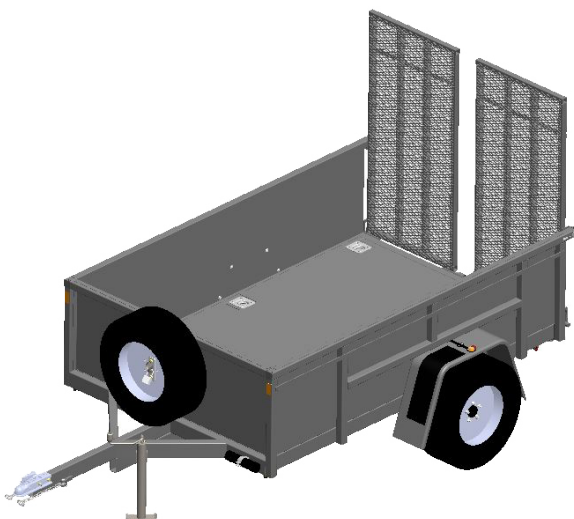



A series of horizontal black lines for writing, filling the majority of the page. The lines are evenly spaced and extend across the width of the page.

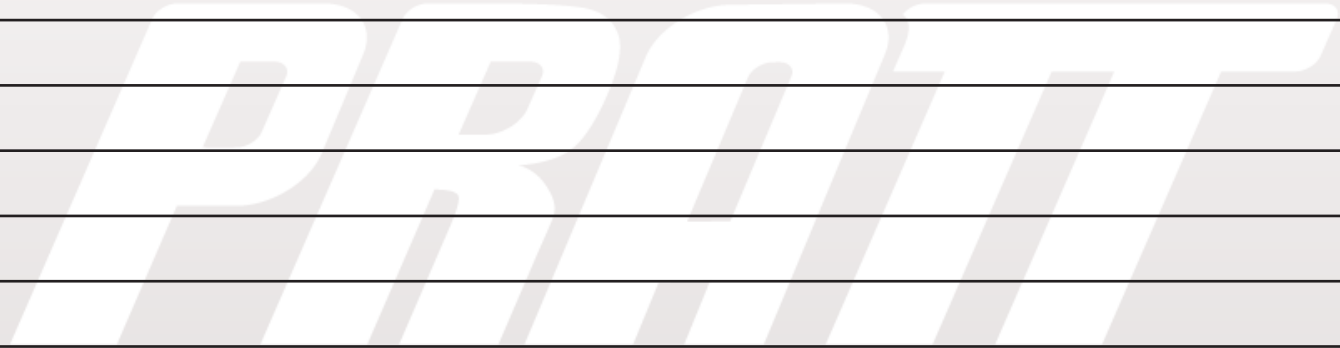

EZU-CF - UTILITY TRAILERS

64" x 98" deck surface

Specifications

Capacities

- Max Payload 1,890 lbs.
- GVWR 2,990 lbs.
- Trailer Weight 1,100 lbs. (Approx.)
- Axle Rating 1 x 3,500 lbs.
- Jack Rating 2,000 lbs.

Dimensions

- Deck Loading Area 64" x 98"
- Overall Length 13'
- Overall Width 7'
- Load Height 21"
- Wheel Size 15"
- Tire Size ST205/75R15D
- Ball Size 2" Ball

Electrical

- DOT Compliant LED Lighting
- Factory Molded Wiring Harness

Standard Features

- 4" x 2" x 11 Gauge Tube Steel Frame
- 2" x 2" x 11 Gauge Tube Crossmembers
- 2" x 8" Treated Wood Decking
- 14 Gauge Steel Sidewalls
- 24" Sidewalls
- Single Spring Axle (No Brakes)
- Built In Recessed D-Rings

Options

- Coupler Lock
- Wheel Lock
- Spare Tire Carrier & Wheel Assembly

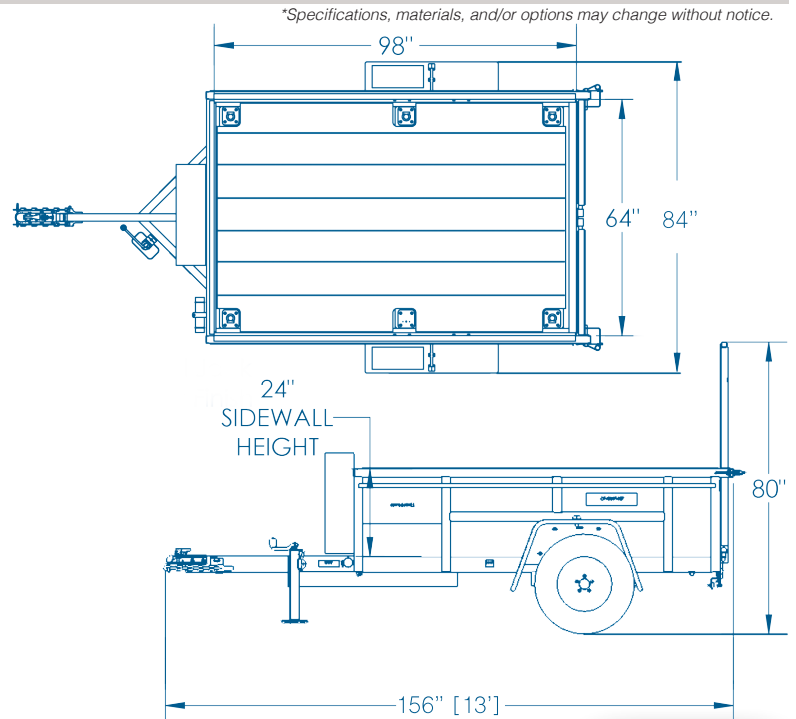
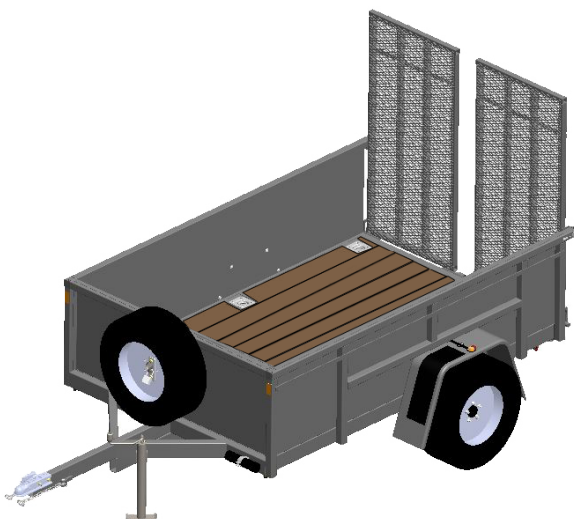

PRATT Industries U.S.
11365 Red Arrow Hwy.
Bridgman, MI 49106

sales@ezrampinc.com
phone : 269.465.7676
fax : 269.465.7677

<https://www.EZrampInc.com/>

Rev 6 2024.04.24





A series of horizontal black lines for writing, starting below the yellow line and ending above the dark blue footer. The lines are evenly spaced and cover most of the page's width.

PRATT





A series of horizontal lines for writing, starting below the yellow line and ending above the footer. The lines are evenly spaced and cover most of the page's vertical space.

PRATT Industries U.S.
11365 Red Arrow Hwy.
Bridgman, MI 49106

sales@ezrampinc.com
phone : 269.465.7676
fax : 269.465.7677

<https://www.EZrampInc.com/>

Rev 6 2024.04.24





A series of horizontal black lines for writing, starting below the yellow line and ending above the dark blue footer. The lines are evenly spaced and cover most of the page's width.

PRATT



PRATT Industries U.S.

11365 Red Arrow Hwy.
Bridgman, MI 49106



phone : 269.465.7676

sales@ezrampinc.com

fax : 269.465.7677



©PRATT Industries U.S. All images and specifications contained in this brochure are based on the latest product information available at the time of publication. Specifications, standard features, options, components, and colors are subject to change without notice. Some features may be subject to availability, delays, or discontinuance. Trailers may be shown with optional equipment. PRATT Industries U.S. reserves the right to make changes in features and specifications at any time without notice. Please contact your authorized PRATT dealer for details.

PRATT Trailers Specifications Rev6 2024.04.24